

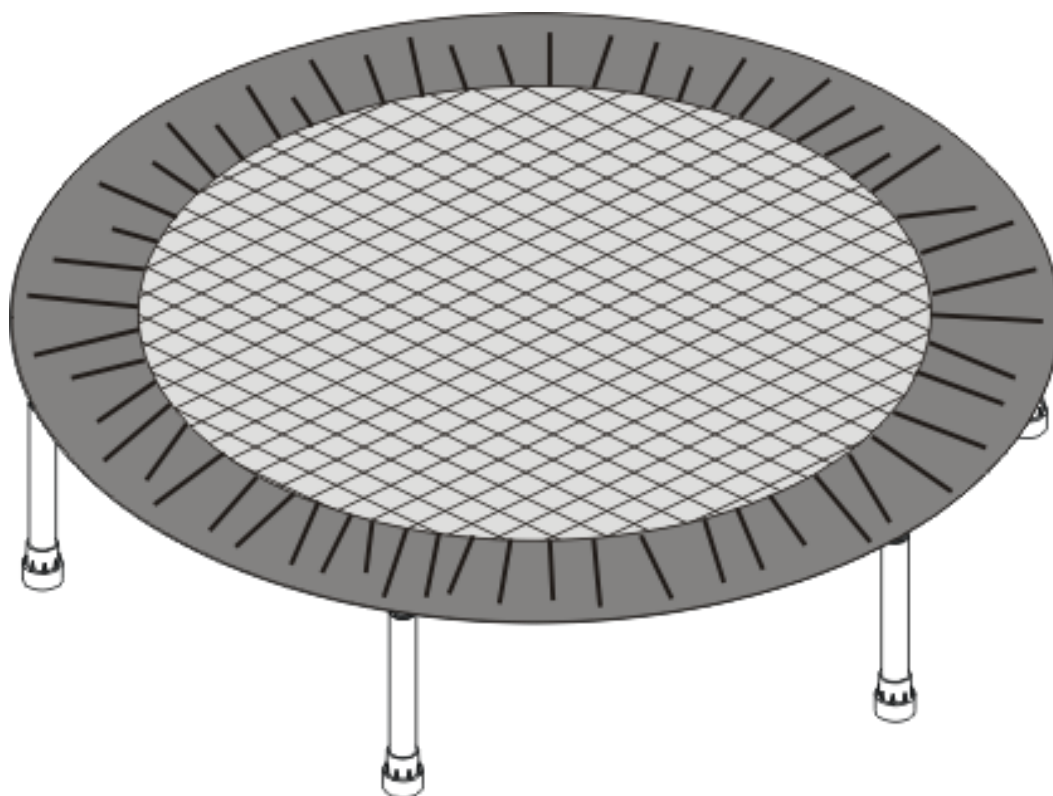

USER MANUAL – EN

**IN 359, 752, 753 Mini Trampoline inSPORTline 96, 122, 140
cm**



Diameter:

<input type="checkbox"/>	36" (91 cm)
<input checked="" type="checkbox"/>	38" (96 cm)
<input type="checkbox"/>	40" (102 cm)
<input type="checkbox"/>	44" (112 cm)
<input checked="" type="checkbox"/>	48" (122 cm)
<input checked="" type="checkbox"/>	55" (140 cm)

CONTENTS

PACKAGE CONTENTS 3
BEFORE YOU START 3
ASSEMBLY INSTRUCTIONS 4
EXERCISES 5
SAFETY INSTRUCTIONS..... 7
 TRAMPOLINE PLACEMENT..... 7
 SAFETY NOTICE OF USING THE TRAMPOLINE 8
TERMS AND CONDITIONS OF WARRANTY, WARRANTY CLAIMS..... 8

READ THIS FIRST!!!

Thank you for purchasing our product.

IN CASE OF MISSING OR BROKEN PARTS, PLEASE CONTACT PLACE OF PURCHASE FOR ASSISTANCE.

PACKAGE CONTENTS

Reference number	Description	36"	38"	40"	44"	48"	55"
1	Frame Pad	1	1	1	1	1	1
2	Top Rail with rubber cap	1	1	1	1	1	1
3	Trampoline Mat	1	1	1	1	1	1
4	Leg Base	6	6	6	6	8	8
5	Safety Cap	6	6	6	6	8	8
7	Spring	32	32	36	38	44	48

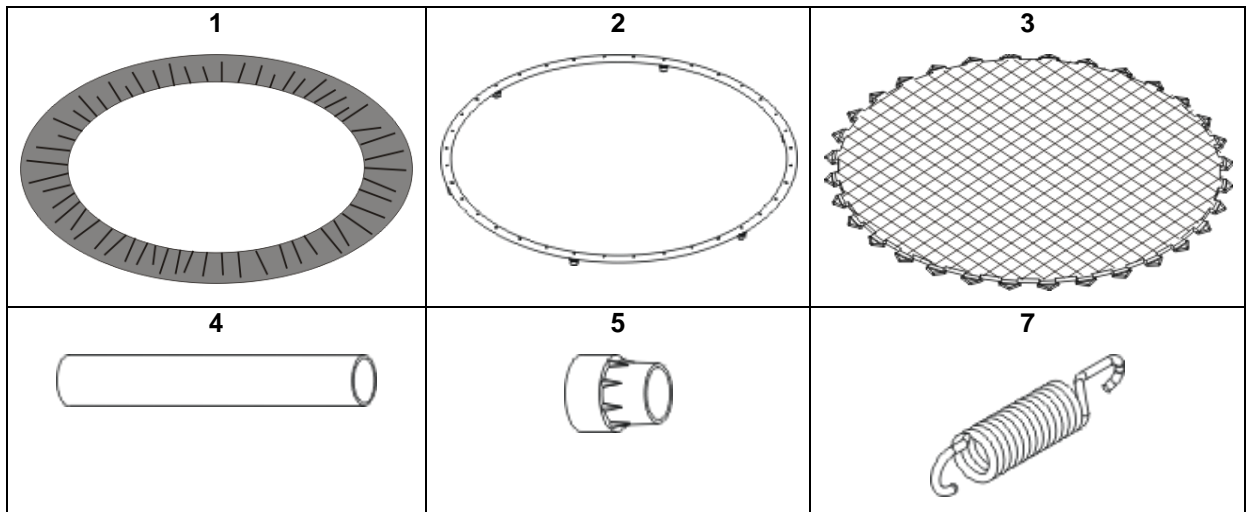

We make every effort to present the most current specifications and product features when printing this literature. However, as a result of our policy for continuous improvement, changes may be made in equipment, availability, specifications and features without notice.

BEFORE YOU START

Refer to Safety Instructions at the back of this instruction booklet.

- Prior to assembling the trampoline, use the above parts list to make sure all parts are present. If any parts are missing, please contact your place of purchase for assistance.
- Please dispose of all packing material carefully and keep it away from children.
- Take a few moments to familiarize yourself with the contents & instructions before attempting assembly.
- When you are ready to start, make sure you have the right tools at hand, adequate space and area for assembly.
- Only assemble by adult. One adult is needed to assemble this trampoline.
- To prevent any injuries to your hands from pinch points during assembly, **please use gloves to protect your hands.**

ASSEMBLY INSTRUCTIONS

ASSEMBLE THE LEG BASE

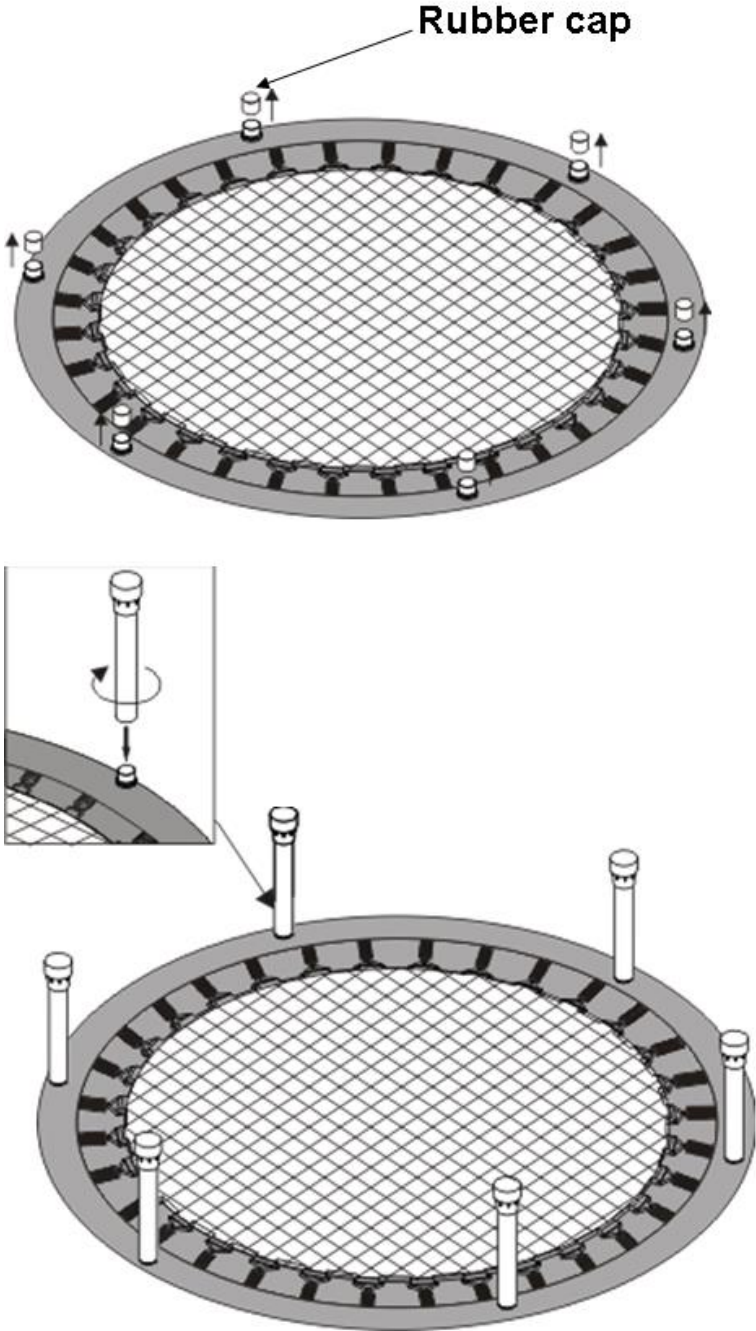

EXERCISES

IMPORTANT: Always warm up thoroughly before starting your workout. Do at least five minutes of stretching to help prevent muscle pulls and strains.

LOW BOUNCE

Bounce upwards only a few inches. Keep the feet 12 to 18 inches apart and bend the knees slightly on take-off and landing.

Perform 1 to 3 minutes.

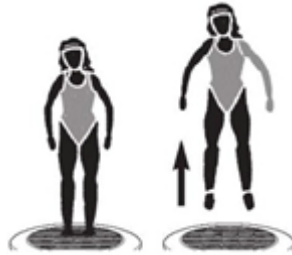

HIGH BOUNCE

Bounce upward from 12 to 18 inches. Start with the feet together with toes pointed downward at the top of each bounce. Spread the feet as you land off each bounce.

Perform 1 to 3 minutes.



JOGGING

Jog in place. Lift the knees and swing arms vigorously. The higher you lift your knees, the better the exercise is for the abdomen.

Perform 1 to 10 minutes.



STRADDLE HOPS

Start with the feet together and arms at the sides. Leap upwards, bringing both arms overhead and spread the feet sideward about 24 inches. On the return bounce, bring the arms to the side and feet together.

Perform 10 to 50 repetitions.



TWISTER

Leap upward while twisting the arms, hips and upper body turning right and the knees twisting left. On the rebound, twist the opposite way.

Perform 10 to 50 repetitions.



HIGH KICK LOW KICK

Leap slightly and kick high with one leg while keeping the hands on the hips. On the rebound do a low kick (about half as high) with the other leg. Continue to alternate high and low kicks.

Perform 1 to 5 minutes.



JOG WITH DUMBBELLS

Hold a light pair of dumbbells (3.3 to 5.5 lbs) in your hands. Jog in place lifting the knees high and moving the arms in rhythm as you jog

Perform 30 secs to 3 minutes.



SIDE & FORWARD LATERALS

Hold the dumbbells with both arms straight down by the side. Bounce on both feet and raise the dumbbells sideward. On the next bounce, raise the dumbbells forward.

Perform 10 to 25 repetitions.



ANKLE & WRIST WEIGHTS

For a more strenuous workout, try using ankle and wrist weights on the exercises shown here.



Time or count your exercises and don't over extend yourself. Start with the minimum times or repetitions and gradually increase to the maximum recommended.

If you combine various exercises and perform them to music, you will enjoy your workouts even more!

WARNING

EQUIPMENT SHOULD BE USED UNDER ADULT SUPERVISION.

	<p>NO MORE THAN ONE PERSON AT A TIME ON THE TRAMPOLINE!</p> <p>MULTIPLE JUMPERS INCREASE THE RISK OF INJURY SUCH AS BROKEN NECK, LEG, BACK OR HEAD INJURY.</p>		<p>DO NOT PERFORM SOMERSAULTS (FLIPS) AS THIS WILL INCREASE RISK OF LANDING ON HEAD OR NECK RESULTING IN INCREASED RISK OF SERIOUS INJURY OR DEATH.</p>
--	--	--	---

SAFETY INSTRUCTIONS

TRAMPOLINE PLACEMENT

The minimum overhead clearance required is 7.3 meters (24 feet). In terms of horizontal clearance, please ensure that no hazardous objects are near the trampoline such as tree limbs, other recreational objects (i.e. swing sets, swimming pools), electrical power wiring, walls, fences, etc.

For safe use of the trampoline, please be aware of the following when selecting a place for your trampoline:

- Make sure it is placed on a level surface.
- The area is well-lighted.
- There are no obstructions under the trampoline.

If you do not follow these guidelines, you increase the risk of someone to getting injured.

IMPORTANT:

- In the interest of your child's safety, it is important that you read both the safety notices and the assembly instructions carefully before allowing your child to use this piece of apparatus.

- Ensure the feet are firmly secured and the fabric surround covers the springs before use.

SAFETY NOTICE OF USING THE TRAMPOLINE

- 1) Caution and care must be taken in the unpacking and assembly of this product. Due to small parts and packaging materials, adult assembly is required.
- 2) Adult supervision of this product is required at all times. Do not leave a child unattended.
- 3) Outdoor use – position away from water on flat firm ground, ideally grass. Never position on or near to hard surfaces such as patios or driveways. Or close to buildings.
- 4) Ensure the area under and around the trampoline is clear of any toys/obstacles that may cause injury.
- 5) Indoors use – position so that there is sufficient ceiling height. Never position immediately below light fitting.
- 6) Recommended age for this trampoline is over 3 years. Maximum weight limit is 100 Kg.
- 7) This trampoline is designed for one user only. Do not let more than one child use this product at the same time.
- 8) Users should not wear clothing that could catch or snag by the product (e.g. loose clothing, cords shoulder bags, jewelry.)
- 9) Users should stand or bounce as near to the center of the mat as possible. Bouncing or standing near the edge of the trampoline could cause the frame to tip over.
- 10) Do not allow small children to wander into the play area while the trampoline is in use.
- 11) Do not allow small children to crawl or hide under the trampoline.
- 12) Discontinue use if any breakage is found. Failure to do this may result injury.
- 13) Not suitable for children under 3 years. This product contains small parts, which may cause choking.

TERMS AND CONDITIONS OF WARRANTY, WARRANTY CLAIMS

General Conditions of Warranty and Definition of Terms

All Warranty Conditions stated hereunder determine Warranty Coverage and Warranty Claim Procedure. Conditions of Warranty and Warranty Claims are governed by Act No. 40/1964 Coll. Civil Code, Act No. 513/1991 Coll., Commercial Code, and Act No. 634/1992 Coll., Consumer Protection Act, as amended, also in cases that are not specified by these Warranty rules.

The seller is SEVEN SPORT s.r.o. with its registered office in Borivojova Street 35/878, Prague 13000, Company Registration Number: 26847264, registered in the Trade Register at Regional Court in Prague, Section C, Insert No. 116888.

According to valid legal regulations it depends whether the Buyer is the End Customer or not.

“The Buyer who is the End Customer” or simply the “End Customer” is the legal entity that does not conclude and execute the Contract in order to run or promote his own trade or business activities.

“The Buyer who is not the End Customer” is a Businessman that buys Goods or uses services for the purpose of using the Goods or services for his own business activities. The Buyer conforms to the General Purchase Agreement and business conditions to the extent specified in the Commercial Code.

These Conditions of Warranty and Warranty Claims are an integral part of every Purchase Agreement made between the Seller and the Buyer. All Warranty Conditions are valid and binding, unless otherwise specified in the Purchase Agreement, in the Amendment to this Contract or in another written agreement.

Warranty Conditions

Warranty Period

The Seller provides the Buyer a 24 months Warranty for Goods Quality, unless otherwise specified in the Certificate of Warranty, Invoice, Bill of Delivery or other documents related to the Goods. The legal warranty period provided to the Consumer is not affected.

By the Warranty for Goods Quality, the Seller guarantees that the delivered Goods shall be, for a certain period of time, suitable for regular or contracted use, and that the Goods shall maintain its regular or contracted features.

The Warranty does not cover defects resulting from:

User's fault, i.e. product damage caused by unqualified repair work, improper assembly, insufficient insertion of seat post into frame, insufficient tightening of pedals and cranks

Improper maintenance

Mechanical damages

Regular use (e.g. wearing out of rubber and plastic parts, joints etc.)

Unavoidable event, natural disaster

Adjustments made by unqualified person

Improper maintenance, improper placement, damages caused by low or high temperature, water, inappropriate pressure, shocks, intentional changes in design or construction etc.

Warranty Claim Procedure

The Buyer is obliged to check the Goods delivered by the Seller immediately after taking the responsibility for the Goods and its damages, i.e. immediately after its delivery. The Buyer must check the Goods so that he discovers all the defects that can be discovered by such check.

When making a Warranty Claim the Buyer is obliged, on request of the Seller, to prove the purchase and validity of the claim by the Invoice or Bill of Delivery that includes the product's serial number, or eventually by the documents without the serial number. If the Buyer does not prove the validity of the Warranty Claim by these documents, the Seller has the right to reject the Warranty Claim.

If the Buyer gives notice of a defect that is not covered by the Warranty (e.g. in the case that the Warranty Conditions were not fulfilled or in the case of reporting the defect by mistake etc.), the Seller is eligible to require a compensation for all the costs arising from the repair. The cost shall be calculated according to the valid price list of services and transport costs.

If the Seller finds out (by testing) that the product is not damaged, the Warranty Claim is not accepted. The Seller reserves the right to claim a compensation for costs arising from the false Warranty Claim.

In case the Buyer makes a claim about the Goods that is legally covered by the Warranty provided by the Seller, the Seller shall fix the reported defects by means of repair or by the exchange of the damaged part or product for a new one. Based on the agreement of the Buyer, the Seller has the right to exchange the defected Goods for a fully compatible Goods of the same or better technical characteristics. The Seller is entitled to choose the form of the Warranty Claim Procedures described in this paragraph.

The Seller shall settle the Warranty Claim within 30 days after the delivery of the defective Goods, unless a longer period has been agreed upon. The day when the repaired or exchanged Goods is handed over to the Buyer is considered to be the day of the Warranty Claim settlement. When the Seller is not able to settle the Warranty Claim within the agreed period due to the specific nature of the Goods defect, he and the Buyer shall make an agreement about an alternative solution. In case such agreement is not made, the Seller is obliged to provide the Buyer with a financial compensation in the form of a refund.



SEVEN SPORT s.r.o.

Registered Office:	Borivojova 35/878, 130 00 Praha 3, Czech Republic
Headquarters:	Delnicka 957, 749 01 Vitkov, Czech Republic
Warranty & Service Centre:	Cermenska 486, 749 01 Vitkov, Czech Republic

CRN: 26847264
VAT ID: CZ26847264
Phone: +420 556 300 970
E-mail: eshop@insportline.cz
reklamace@insportline.cz
servis@insportline.cz
Web: www.insportline.cz

SK

INSPORTLINÉ s.r.o.

Headquarters, Warranty & Service centre: Elektrická 6471, 911 01 Trenčín, Slovakia

CRN: 36311723

VAT ID: SK2020177082

Phone: +421(0)326 526 701
E-mail: objednavky@insportline.sk
reklamacie@insportline.sk
servis@insportline.sk
Web: www.insportline.sk

Date of Sale:

Stamp and Signature of Seller: